

# **At a Crossroads: Reconsidering Gender and Identities**

**Department of History and Art History  
University of Otago, Dunedin**

**4-5 April 2013  
Colloquium Programme**

**Conveners: Armando Alfaro, Erin C. M. Grant, Hilary  
Radner**

Sponsored by: Department History and Art History; Division of Humanities Research Network Cultures, Histories and Identities in Film, Media and Literature; Comparative and Cross-Cultural Studies Research Theme; Department of Sociology, Gender and Social Work; Department of English and Linguistics.

	<b>Thursday 4 April 2013</b>
Time	
9:15 – 9:30 am	Registration Central Library, CEN 1
9:30 – 10:00 am	Welcome  Professor Paul Trebilco, Acting PVC, Humanities Professor Tony Ballantyne, HOD, Department of History and Art History Armando Alfaro, Colloquium Co-Convener  CEN 1
10:00 – 11:00 am	<b>Session 1: Revisiting Media Stereotypes</b> Chair: Judith Collard <b>Location: CEN 1</b>  Armando Alfaro – “Suffering from Realness: Kanye West and the Contradictions of Masculinity In Hip Hop”  Hilary Radner – “Gender, Space and the City: The Apartment in <i>La Peau douce</i> ( <i>The Soft Skin</i> , François Truffaut, 1964)”
11:00 – 11:30 am	<b>BREAK</b>
11:30 – 12:30 pm	<b>Session 2: Gender and Space</b> Chair: Fiona Bakas <b>Location: CEN 1</b>  Judith Collard – “Neil Emmerson’s ( <i>habit@t</i> ): Queering Masculine Spaces”  Catherine Dale – “Crossing Roads: The Self-Perpetuation of the Heterosexual Gender Divide”
12:30 – 2:15 pm	<b>LUNCH</b>

<p>2:15 – 3:15 pm</p>	<p style="text-align: center;"><b>Session 3: Traveling Subjects</b> Chair: Armando Alfaro <b>Location: CEN 1</b></p> <p>Rosey Anderson – “At the Border: A Case Study of Gender and Immigration in New Zealand”</p> <p>Maud Ceuterick – “Women and Spaces In-between: Contemporary Moving Images and Nomadic Subjects”</p>
<p>3:15 – 3:45 pm</p>	<p style="text-align: center;"><b>BREAK</b></p>
<p>3:45 – 4:45 pm</p>	<p style="text-align: center;"><b>Session 4: Contemporary Masculinities</b> Chair: Steve Sexton <b>Location: CEN 1</b></p> <p>Alistair Fox – “Genre And Gender In Mike Wallis’s <i>Good For Nothing</i> (2011): Contemporary New Zealand Cinema and ‘The Demise of Guys’”</p> <p>Leigh Paterson – “Manvertising: A Critical Appraisal of Communication Design in the Masculinisation of Consumables”</p>
<p>4:45 – 5:10 pm</p>	<p style="text-align: center;"><b>BREAK</b></p>
<p>5:15 – 6:15 pm</p>	<p style="text-align: center;"><b>KEYNOTE: BARRY REAY</b> “Blurring Boundaries: Contesting the Narratives of Transsexuality” <b>Location: Burns 5</b></p>
<p>6:30 – 7:30 pm</p>	<p style="text-align: center;"><b>RECEPTION: OMBRELLOS</b> <b>10 Clarendon Street</b></p>

	<b>Friday 5 April 2013</b>	
9:30 – 11:00 pm	<b>Session 5: Literature</b> Chair: Catherine Dale <b>CEN 1</b>	
	<p>Sharon Matthews – “‘Disturbed’ Masculinities in the Plays of James K. Baxter”</p> <p>Bumbekile Ncube – “From Gender Conflict to Existential Crisis: Power Relations and the Gendered (Post)Colonial Subject in Tsitsi Dangarembga’s <i>Nervous Condition</i> and Keri Hulme’s <i>The Bone People</i>”</p> <p>Bradley Watson – “Competing Expectations: Reconsidering the Samoan Woman’s Body in Tusiata Avia’s Poetry”</p>	
11:00 – 11:30 pm	<b>BREAK</b>	
11:30 – 12:30 pm	<b>Session 6: Gender and Medical Discourses</b> Chair: Lee Smith <b>CEN 1</b>	<b>Session 7: Gender and Embodiment</b> Chair: Maud Ceuterick <b>CEN 3</b>
	<p>Marita Leask – “A Woman’s Ability to Choose: A Genealogical Examination of the Link between Abortion and Mental Health”</p> <p>Fred LeBlanc – “‘Just tell them you want bottom surgery’”: Transnormativity in Medical Practice and the Desire for Androgyny”</p>	<p>Jonathan W. Marshall – “Hystericisation and the Impossibility of Gender Legibility: A Heuristic for the Description of Non-Emergence”</p> <p>Marialuisa Risoli – “Pornographic Encounters: The Experience of Flesh in Angela Carter’s Fairy Tales”</p>
12:30 – 1:30 pm	<b>Lunch</b>	

<p>1:30 – 3:00 pm</p>	<p><b>Session 8: In and Out of School</b> Chair: Fred LeBlanc <b>CEN 1</b></p> <p>Karen Nairn – “Children of Rogernomics: How Does This Neoliberal Generation ‘Do’ Gender?”</p> <p>Lee Smith and Kim Brown – “Femininity: The New and Not So New Options Available to Young Women in Aotearoa/New Zealand”</p> <p>Steven Sexton: “Macho to Metrosexual: How Secondary Students Are Defining and Displaying Their Masculinity”</p>	<p><b>Session 9: Social Reproduction</b> Chair: Annabel Cooper <b>CEN 3</b></p> <p>Carole (Shire) Agnew – “Menstruation: A Foundation Stone to the Educational ‘Sexuality Highway’”</p> <p>Georgia Knowles – “Changing Representations of Gender and Rape: An Analysis of Rape Prevention Poster Campaigns”</p> <p>Fiona Eva Bakas – “Re-Negotiation of Gender Roles and Relations Related to Social Reproduction in Tourism Handicraft Entrepreneurs: Greek Ethnographic Case Studies”</p>
<p>3:00 – 3:30 pm</p>	<p><b>BREAK</b></p>	
<p>3:30 – 4:45 pm</p>	<p><b>ROUNDTABLE: “Reconsidering Gender and Identities”</b> <b>CEN 1</b> Convener: Barbara Brookes Armando Alfaro, Annabel Cooper, Charlotte Macdonald, Jonathan W. Marshall</p>	
<p>4:45 – 5:15 pm</p>	<p><b>BREAK</b></p>	
<p>5:15 – 6:15 pm</p>	<p><b>KEYNOTE: CHARLOTTE MACDONALD</b> “‘It’s good to be a guy’: Valuing Gender in the Early Twenty-first Century”</p> <p><b>Location: Burns 5</b></p>	

## Locations

Presentations, unless otherwise noted, will take place in the conference rooms of the University of Otago Central Library (ISB) located on the first floor, CEN 1 and CEN 3, as indicated in the programme. Keynotes are located in Burns 5.

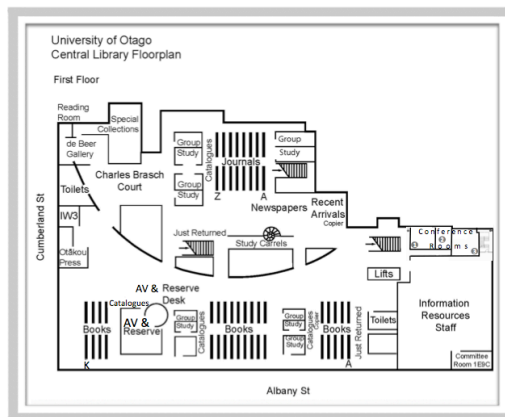
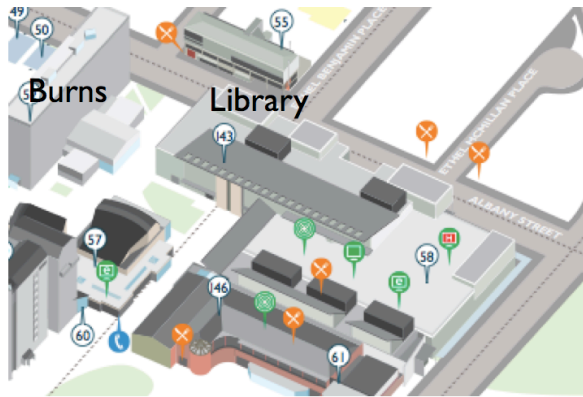

The reception, Thursday 4 April at 6:30, will be held at Ombrellos, 10 Clarendon Street

